

**Karlsruher Glastechnisches Werk
Schieder GmbH**

Germany
76185 Karlsruhe
Gablonzer Strasse 6
Tel. 0049 / 721 / 95897-0
Fax. 0049 / 721 / 95897-77
eMail: info@kgw-isotherm.de
Internet: [www.kgw-isotherm.de\(com\)](http://www.kgw-isotherm.de(com))

Information for

**Distribution
Technology
and
User**

KGW - ISOTHERM

Company Conception

The experience of over 50 years in manufacturing vessels and systems for storage and transportation of liquid gases, tempering and insulation of laboratory glassware and metal ware enables our company to manufacture and distribute high-quality KGW - ISOTHERM products for the branch of research and technology. The regularly verified quality of the materials used in the production process as well as a continuous quality inspection during the manufacturing of KGW - ISOTHERM products have created an enormous confidence between user and manufacturer. Modern methods in development (CAD) and manufacturing of products, as well as practising a certified quality management according to DIN EN ISO 9002 have grown the confidence in KGW - Isotherm products.

Apart from the extensive supply range described in the catalogue, KGW - ISOTHERM manufactures customer specific devices and containers in both serial and single-piece production.

Range of Standard Products of the KGW -ISOTHERM Catalogue

Products or Product Groups	Content	catalogue page
Dewar flasks cylindrical	0,1 to 8 litres	5 - 8
Dewar flasks with flange and thread	0,1 to 8 litres	9 - 12
Dewar flasks with flat bottom	0,15 to 2,1 litres	13 - 14
Dewar flasks dish-shaped	0,08 to 5,8 litres	15 - 18
Dewar flasks with lid and handle	1 to 40 litres	19 - 24
Insulating boxes	30 to 150 litres	25 - 26
Dewar flasks spherical	1 to 10 litres	27 - 28
Tempering beakers	0,25 to 6 litres	29 - 30
Waste disposal tanks	4 to 15 litres	31 - 32
Dewar flasks cylindrical made of V2A	0,5 to 6 litres	33 - 34
Hot and cold protection devices	-100 to +600°C	35 - 36
Cold traps and vacuum pump devices		37 - 42
Storage container for LN2 and accessory	7 to 300 litres	43 - 50
Biological LN2 storage container	3 to 40 litres	51 - 52
KALTGAS tempering systems	-170 to +250°C	53 - 54
Reaction vessels and Bio-reactors	0,25 to 15 Liter	55 - 74
Columns		75 - 80

Material - Glass

All the glassware produced by KGW - ISOTHERM are made of borosilicate glass 3.3 DIN/ISO 3585. The glass has the following characteristics:

Chemical characteristics	hydrolytic resistance	: according to DIN-ISO 719 (98°C)
	acid resistance	: according to DIN12116, acid class 1
	acid resistance	: according to DIN-ISO 1776
	alkaline resistance	: according to DIN 52322
	alkaline resistance class	: according to DIN 52322-A2 : according to ISO 695-A2
Optical characteristics	spectrum region, where the absorption is negligible low	: 310-200 mm
Physical characteristics (at 20°C-300°C)	linear expansion factor	: $3,3 \times 10^{-6}$ 1/K
	density	: 2,23 g/cm ³
	specific thermal capacity	: 910 J/kg K
	transformation temperature	: 525 °C

Admissible Operation Conditions for Standard Glass Flasks

Temperature range Dewar	-200°C to +200 °C
Temperature range other components	-10°C to +80 °C
Pressure range	depressurised

Standard - Dewar flasks are not appropriate for the use of liquid and gaseous helium.
Special design is available on request.

Standards and Guidelines

All of the KGW glassware are manufactured considering "Guideline of pressure devices", directive 97/23 EC and DIN 12492 "Equipment with vacuum insulation". Under the condition that there are any standards for joint parts such as spherical ground joints or conical ground joints, those will be utilised (e.g. DIN 12242-1 and DIN 12244-1).

Verifications

Each of the KGW –ISOTHERM products is subject to individual verification and identification, as well as the documentation of all manufacturing data.

Besides the verification means of quality management the following testing devices are available for KGW – ISOTHERM directions to disposition:

- Testing device for measurement of the LN2 evaporation rate
- Helium leak test device
- Ultrasonic wall thickness measuring instrument
- Vacuum measuring and calibration device
- Temperature measuring and calibration device
- Water and compressed-air testing device for reaction vessels
- Temperature testing device for columns

For the evaporation rates of Dewar flasks mentioned in the catalogue, the flasks were covered with the appertaining lid respective plug, and were verified with the coolants (liquid nitrogen, or dry ice) mentioned in the catalogue. The figures (evaporation rate) are stated in the catalogue in L/h (litres per hour) or as holding time in hours.

Dewar Flasks Made of Glass

Construction and Function of Dewar Flasks

Dewar flasks are double walled vacuum insulated flasks made of glass or metal, which have the task to thermally insulate a therein-stored product (LN2; CO2 etc.) against the ambient temperature. Dewar flasks consist of an inner and an outer recipient, which are connected on top at the filling port. The space between the inner and the outer flask is vacuum insulated, to stop the heat contact between the product stored in the Dewar flask and the ambient temperature (contact warmth). Additionally, Dewar flasks made of glass have a silver coating in the vacuum space, in order to minimise the warmth radiation. The best possible insulation could be received by reducing the contact warmth and the radiation warmth.

Silvering Types

The silvered Dewar flasks made of glass, are distinguished between fully silvering, viewing stripes with viewing stripes silvering, and non-silvering (non-silvered – transparent).

The smallest radiation loss (radiation warmth) will be obtained with the fully silvering and there with the longest holding time of the coolant stored in the Dewar flask. By attaching a viewing stripe in the silvering of a Dewar flask, the reflection of the radiation warmth and therewith the insulating capacity will be changed. The wider a viewing stripe or the more viewing stripes are attached, the greater is the conduction loss of the coolant stored in the Dewar flask.

The diagram “D1” shows the evaporation rates of liquid nitrogen in a Dewar flask type 15 C with different silvering versions.

Diagram “ D1“

Warmth Conductance of a Dewar Flask’s Material

Besides the insulation, the warmth conductance of the material (glass or metal) from which a Dewar flask is made of, is also a deciding factor for the actual insulating capacity. The higher the warmth conductance of the material, the higher is the warmth drag-in in the Dewar flask and the lower is the holding time of the coolant stored in the Dewar flask (LN2 or CO2).

Another important point is the non-vacuum insulated surface of a Dewar flask. Herewith is meant the opening of the Dewar flask. Over this opening, the greatest warmth drag-in occurs in the Dewar flask. The better the Dewar flask is insulated in the opening region with a lid or plug, the longer is the holding time of the stored coolant.

Example: Two cylindrical Dewar flasks with different diameter and almost equal volume.

Type	Volume	Shape	Inner Diameter	Inner Height	LN2 Holding Time
1) 14 C	3,2 litres	cylindrical	90mm	600mm	193 hours
2) 20 C	3,0 litres	cylindrical	138mm	230mm	55 hours

Example: A cylindrical Dewar flask with different plug material.

Type	Volume	Material	Inner Diameter Plug	Inner Plug Height	LN2 Holding Time
1) 20 C	3,0 litres	*Latizell	138mm	20mm	55 hours
2) 20 C	3,0 litres	*PU	138mm	20mm	60 hours

* Latizell is foamed polyethylene

* PU is highly solidified polyurethane-foam

Diagramm D1
Type 15 all silvering versions
measured with PU plugs

- 1) fully silvered
- 2) one viewing stripe 1,5cm
- 3) two viewing stripes 1,5cm
- 4) two viewing stripes 2,5cm
- 5) viewing stripe 1/3 of girth
- 6) non-silvered

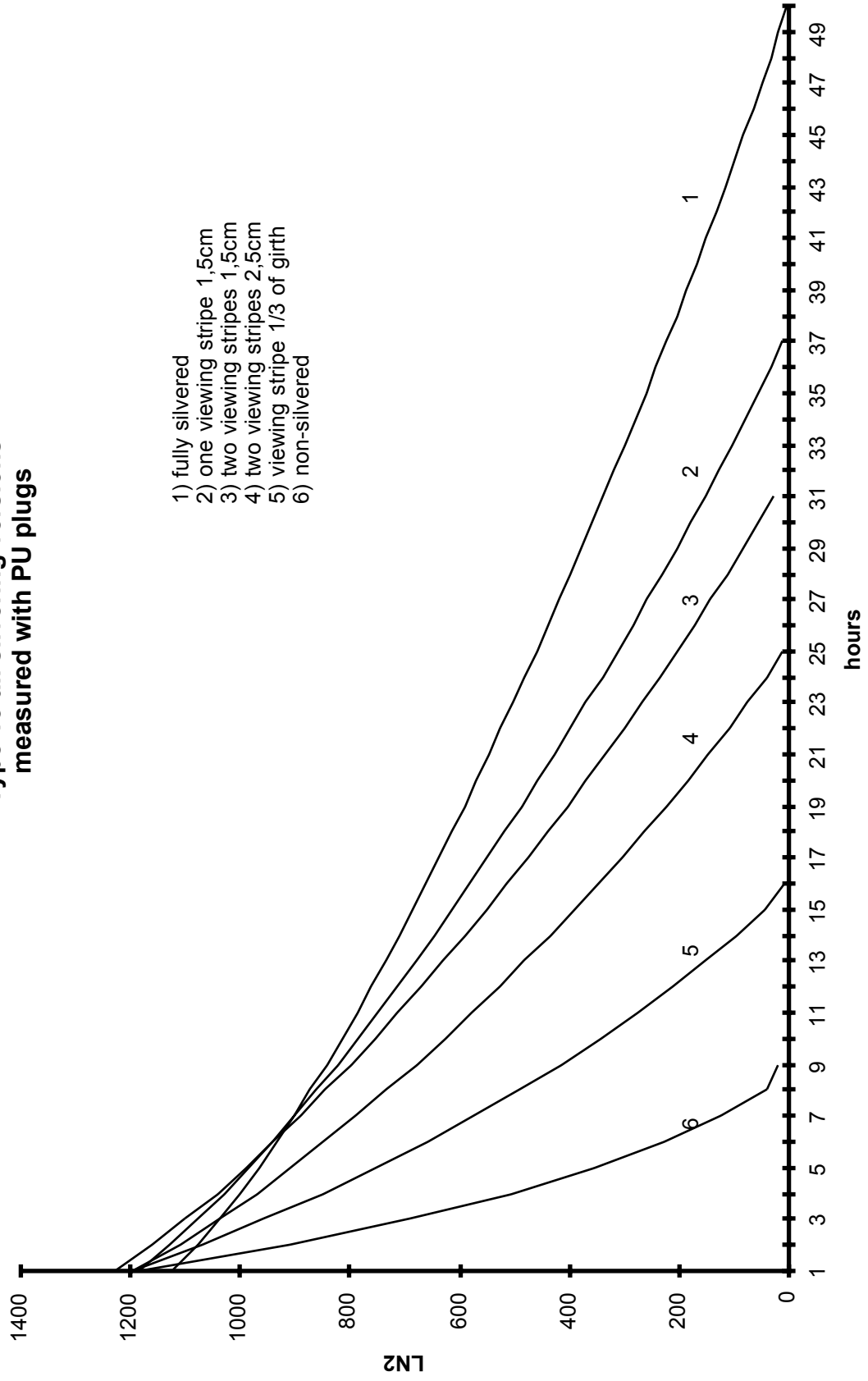

Dewar flasks cylindrical	Type	00 C - S 22 C	catalogue page 4 - 5
Dewargefäße flasks cylindrical with handle	Type	G 0 C - GS 22 C	
Refill glasses for Dewar flasks cylindrical	Type	00 A - S 22 A	catalogue page 6 - 7
Plugs for Dewar flasks cylindrical			

Cylindrical Dewar flasks are used as insulating flasks at laboratory benches. Dewar flasks could store thermally insulated coolant such as liquid nitrogen or dry ice as well as hot media such as hot oil. For the used glass (borosilicate glass 3.3 according to DIN/ISO 3585) are usable for high temperatures, is it necessary to take the maximum operating temperature into consideration especially with the usage of the plug or lid material.

The Dewar flasks could be find at almost every laboratory place, for the flasks are available in many different sizes and dimensions. Dewar flasks are efficient, vacuum insulated containers, and therefore have an extensive field application.

- short term storage and transportation of coolants e.g. liquid nitrogen (LN2), dry ice (CO2)
- freezing of biological samples
- combined with cold traps for gas cleaning by condensation
- short term storage of frozen materials
- cryotransfer (shock freezing)
- storing and transfusing of hot or cold liquids
- usage for calibrating of temperature measuring cells, or temperature sensors
- usage for chemical reactions, where the thermal flow must be minimal (e.g. verification of the reactivity of fine limes, cement)
- etc.

Available Versions

- fully silvered (standard version)
- silvered with viewing stripes (for observation of reactions or level)
- non-silvered (attention, increased cooling agent consumption)
- shortened (please indicate desired inner height or volume)

Available protection cover – see drawing “ Cylindrical Dewar flasks type 00 to S22“

For improving the flasks' insulation capacity, the Dewar could be provided with a loosely lent plug (accessory, see page 7 - 8). The standard offer are plugs made of Latizell. On request, plugs are available with a higher insulating capacity made of PU.

In case different dimensions or volume, then those shown in the table of the standard Dewar flasks, are required, the enclosed questionnaire could be completed and sent to KGW to work out an offer. All the Dewar flasks listed in the catalogues are also available in lengthened or shortened version. Besides the diameters mentioned in the catalogue, special dimensions could be offered as well. For this, documents of the tube manufacturer (Schott - Rohrglas) are at disposal, or with higher number of pieces, Dewar flasks could be blown in special designs. Thus, not only the diameter but even the shape could be adapted to the customer's wishes. For working out the need flask, please you the enclosed questionnaire.

Cylindrical Dewar flasks type 00 - S22

Type "A"
Glass refill

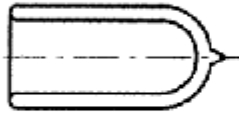

Type "D"
glass Dewar with
bottom cap
made of metal
special design



Type "C" standard
cover ALU smooth
blue coated



Type "G-C" standard
cover ALU smooth
blue coated with
handle



Type "CAL" special
design, cover
ALU Stucco



Type "G - CAL" special
design, cover
ALU Stucco with handle

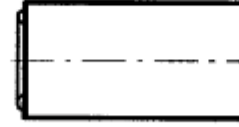

Type "C-E" special
design, cover
made of stainless steel



Type "G-C-E" special
design, cover made of
stainless steel with handle

Questionnaire for a Dewar Flask

Please respond to the listed questions and return us this information. We will work out a quotation with a drawing and send it to you as soon as possible.

1) Operating temperature

Temperature range from +°C to -°C

2) Desired dimensions of the inner Dewar flask

a) Inner diameter cm

b) Inner height cm

3) Desired dimensions of the outer Dewar flask

a) Outer diameter cm

b) Outer height cm

4) Silvering

a) Fully silvered ()

b) One viewing stripe ()

c) Opposite viewing stripes ()

d) Non-silvered ()

5) Protection cover

a) Aluminium stucco ()

b) Aluminium blue coated ()

c) V2A ()

d) Sheet metal blue coated ()

6) Cap version

a) Insulated plug ()

b) Insulated lid ()

b) Flange () size

c) Thread () size

7) Further comments or customer wishes

.....
.....

Sender: Company

Street

Town/City

Contact person

Department

Telephone Fax

Please fax to: KGW-ISOTHERM 00 49 / 721 / 958 97-77

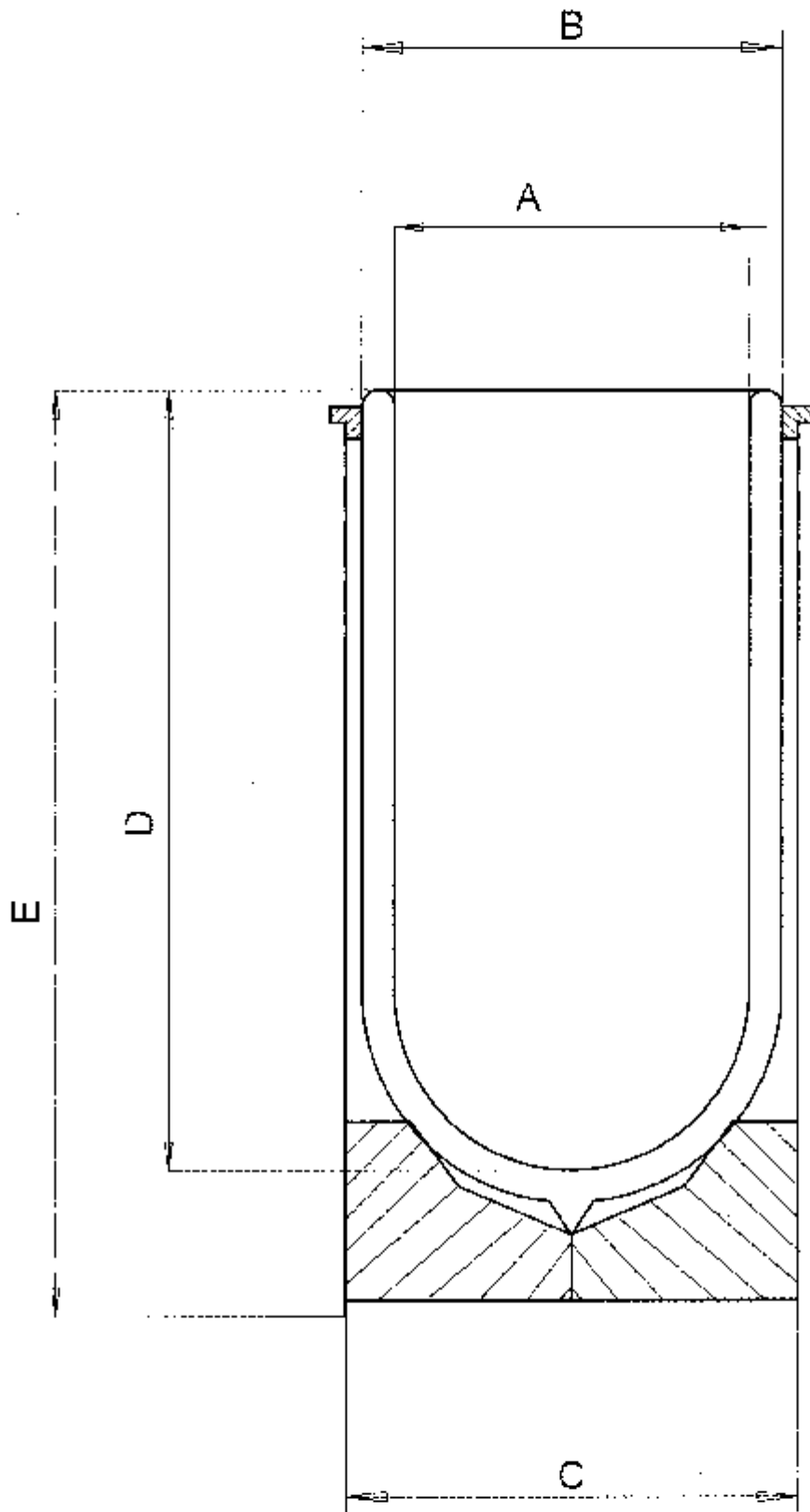

Dewar flasks with screw flange	Type GEW	catalogue page 9 - 10
Dewar flasks with Schott-flange NW	Type NF	catalogue page 11 - 12
Dewar flasks with plane flange	Type F	

Dewar flasks type GEW, NF and F are flasks, with which a gas tight plug is possible. In general, the flasks are fitted in the devices or systems, and therefore, are not classified under the sector of typical laboratory equipment.

Type GEW	Dewar flask with glass flange	DIN 12216
Type NF	Dewar flask with lab plane flange NW with O-ring groove	DIN 12214
Type F	Dewar flask with directly rolled up plane flange	

Besides the listed sealing systems, different sealing or joint parts could be melted on the Dewar flasks. Those could be e.g. a conical ground joint, a spherical ground joint or a glass small flange from the vacuum space, see drawing

“Dewar flasks with connections versions of the products catalogue page 9 – 12“

By the Dewar flasks' utilisation with gassing substances (e.g. dry ice, liquid nitrogen), is it necessary that there is a waste gas hole in the lid, or that the occurring gas in the vessel could be drain off. In case, there is not any waste gas drilling, is it likely that an overpressure could occur in the flask, which would destroy it (danger of explosion). Please consider the “Guideline for pressure devices”, directive 97/23 EG. These kind of Dewar flasks are available in three versions.

Versions

- Type A Refill glass made of glass silvered and evacuated.
- Type C Dewar flask in a blue-coated aluminium protection cover
- Type D Glas -Dewar flask mounted in a metal bottom cap

Dewar flasks with flatt bottom Type FB catalogue page 13 – 14

The flat bottom Dewar flasks have the same field of application as the cylindrical Dewar flasks type 00- S22 (page 5 - 8), however, have a flat inner and outer bottom. Due to the small distance between the inner and outer bottom, these flasks are preferred to utilise on magnet stirrers. In comparison to the low height, these flasks have a high volume.

Dewar flasks of type “FB“ are offered with a structure aluminium protection cover. On request, the Dewar could also be delivered in “A“ version without protection cover, for fitting into a customer owned protection cover.

Dewar flasks dish-shaped Type SCH catalogue page 15 - 16

Dish-shaped Dewar flasks are often used for cooling spherical glass recipients, e.g. with rotary evaporator or with freeze drying system. Due to the large opening, the Dewar flask is also preferringly used for freezing smaller parts (e.g. biological samples or in the pathology). Smaller samples could be dipped in liquid nitrogen with a tweezers to shock freeze the sample. The Dewar flask has an aluminium protection cover and is suitable for utilisation on magnet stirrers.

Dewar flasks type “SCH“ are offered with a structure aluminium protection cover type CAL. On request, the Dewar could also be available in “A“ version as a glass refill.

Dewar flasks with sealing versions of products catalogue page 9 - 12

Dewar flask with
standard ground joint
NS14/23 to NS45/40
DIN 12 244

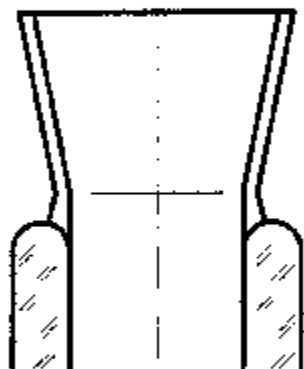

Dewar flask with
spherical ground joint
S13 to S64
DIN 12 244

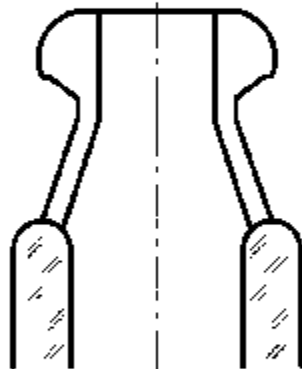

Dewar flask with
vacuum small flange
KF-NW16 to NW50

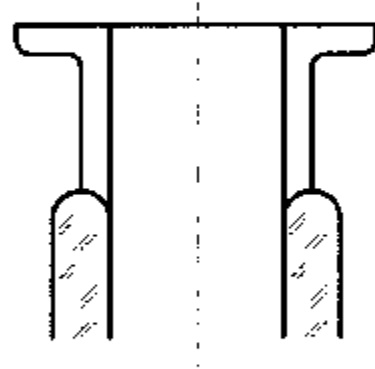

Dewar flask with
standard thread
GL18 to GL45
DIN 12 216

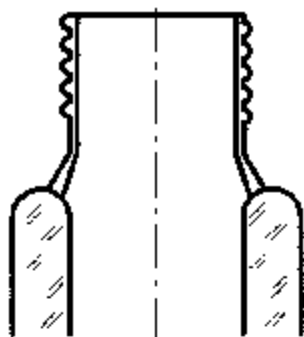

Dewar flask with
Schott flange
NW60 to NW200
DIN 12 214

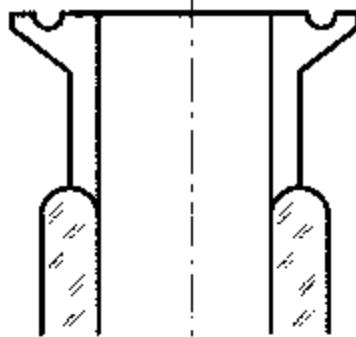

Dewar flask with
rolled-up
flange

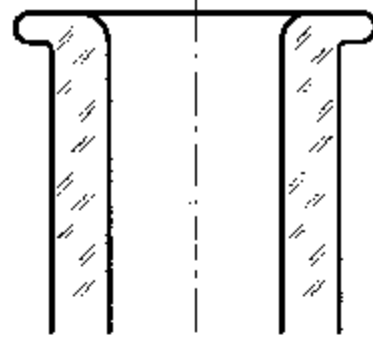

Dewar flask with
plane or saddle flange
DN15 to DN200

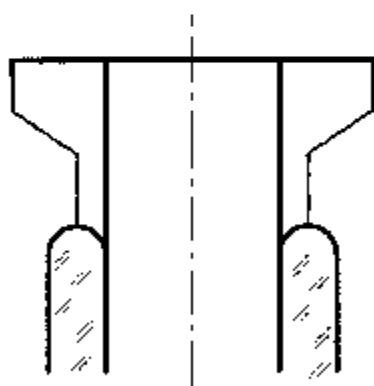

vacuum range

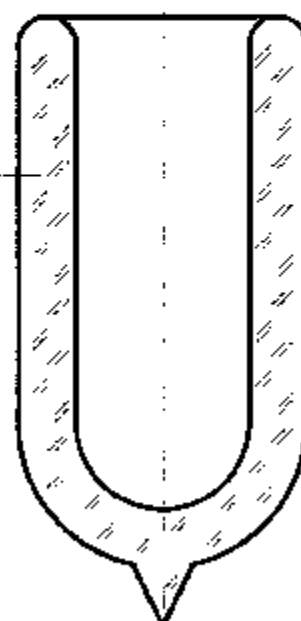

**Dewar flasks and tempering beakers
for magnetic stirrer**

**Type MRD-E
Type MRT-E**

catalogue page 17 - 18

MRD-E and MRT-E are Dewar flasks and tempering beakers, which could be safely and firmly put on a magnetic stirrer. The magnetic stirrer's little rods can freely turn in the Dewar flask type MRD-E or the tempering beaker type MRT-E, for type MRD-E has a dished boiler end (a softly curved, almost flat bottom) and type MRT-E has a flat bottom. Type MRD-E is used as an especially good insulated impeller type mixer, whereas type MRT-E offers the opportunity of tempering liquids, which have to be thoroughly mixed. The field of application of both containers is in those ranges, where liquids have to be homogeneous thoroughly mixed. Dewar flasks of type MRD-E are especially suitable for utilisation, with which the outer heat flow has to be minimal (e.g. determination of reaction heat of chemical reactions). The tempering beakers of type MRT - E are especially suitable for applications, with which a certain temperature of the medium has to be kept constant while thoroughly mixing (biotechnology).

Types MRD 1-E and MRT 1- E are designed for using on the magnetic stirrer type COLOR SQUID from company IKA.

Types MRD 2-E and MRT 2-E are designed for using on the magnetic stirrer type IKAMAG REO from company IKA.

Types MRD 3-E and MRT 3-E are designed for using on the magnetic stirrer Heidolph MR 3000.

As special designs, Dewar flasks and tempering beakers could be manufactured with different volumes or for different magnetic stirrers.

Dewar carrying flasks

Type 26 – 29

catalogue page 19 - 20

Dewar flasks of type 26 to type 29 are cylindrical Dewar flasks with lid, which are used for the short distances transport and short-term storage of heat-sensitive goods (e.g. dry ice, biological samples, etc.). The flasks have a blue-coated metal cover or a stainless steel cover, an aluminium-carrying handle, and an insulated lid with release clamp.

The flasks are suitable for the use of gassing substances (e.g. dry ice, liquid nitrogen).

For safety reasons and according to the prescription by law (TRB) of the Federal Republic of Germany, before utilisation with gassing substances is it necessary to drill a waste gas hole of about 2 mm diameter that no overpressure could occur. The standard version of the lid is without a waste gas hole. If necessary, the hole could be drilled in the lid with a fast running drill.

Large Dewar insulating flasks

Glass refill for large Dewar insulating flasks

Large Dewar insulating flasks box-shaped

Type 30/4 – 35 catalogue page 21 - 22

Type 40 – 47

Type 130 – 131 catalogue page 23 – 24

Large insulating Dewar flasks are used for storage and transportation of heat sensitive goods e.g. dry ice (CO₂). These are especially suitable for storage of dry ice, for the holding time (evaporation rates) is higher than with conventional insulated containers. To store the dry ice safely, we recommend using a linen sac (accessory). The flasks with 28 and 40 litres are generally supplied with a linen sac. To increase the holding time of dry ice in these containers, an insulating disc should be used additionally. This disc is to be put loosely at the head of the container, and lies therewith insulating on the dry ice.

The large insulating Dewar flasks type 30/4 – 35 (4 to 40 litres) have a loosely lain insulated lid with handle. The flasks with a volume of 4, 7, 10, and 14 litres are fitted with a carrying strap. The flasks with a volume of 21, 28 and 40 litres have two hinged pattern handle on the side for carrying the flasks.

The Dewar insulating flasks box-shaped of type 130-135 are distinguished because of their high stability. They are fitted with two hinged pattern handles on the side and an insulated lift-up lid. The over-pressure safety integrated in the lid ensures that no overpressure will build up in the flask when using gassing coolants.

Large insulation box

Type COB

catalogue page 25 – 26

Construction

Large insulation boxes are double walled foamed boxes made of glass fibre reinforced polyester. The boxes consist of an insulated lower part and an insulated lid with an insulating thickness of 60 to 90 mm. The boxes are firmly lockable.

Utilisation and Field of Application of Large Insulation Boxes

The large insulation boxes type COB with a volume of 50 to 150 litres are utilised for storage and transportation of heat sensitive goods (e.g. food, biological samples, and dry ice).

The boxes are designed for the temperature range -70°C to $+80^{\circ}\text{C}$. Due to the gel-Coat coating, the COB boxes are according to the guidelines for food transportation.

Both dry ice and cooling accumulators could be used as coolants. Roller bases for the boxes are offered as accessory. Comparing the evaporation rates of CO_2 shows that the glass Dewar flasks (type 30 /4 – 35, and 130 - 135) insulate for several times better than the large insulation boxes COB. The mechanical strength is a substantial advantage of the COB boxes in contrast to the glass Dewar flasks. The COB boxes are provided with an over-pressure safety when used with CO_2 .

COB boxes are also utilised as test chambers for thermal tests. In this connection, it is possible to run temperatures of $+80^{\circ}\text{C}$ to -100°C in such a box. For tempering the box, a Kaltgas system is mainly used.

Dewar flasks spherical

Type 21 – 24

catalogue page 27 – 28

Spherical Dewar flasks were especially designed for storage and transportation of liquid nitrogen. Due to the small opening profile section, these flasks show a small evaporation rate of LN_2 .

The flasks have a carrying strap and a loosely lain insulated lid. On request, these flasks are also available with viewing stripes to control the level. For the Federal Republic of Germany, these flasks are also offered in a GGVS conform version

Tempering beaker made of glass

Type T

catalogue page 29 - 30

Tempering beaker made of stainless steel

Type TSS

catalogue page 29 - 30

Construction

Tempering beakers are double walled flasks made of glass or metal, in which a tempering liquid is lead through the double wall, and a therein-stored medium could be heated or cooled. The tempering takes place either with a thermostat or with a water-cooling.

Utilisation and Field of Application of Tempering Beakers

Tempering beakers are used for tempering of liquids or solid substance. Often, they are utilised with circulating thermostats. The connection of the tempering jacket occurs with tube olives. However, flanges, couplings or thread connections with tube olives.

Tempering beakers made of glass are mechanical not that severely capable than tempering beakers made of stainless steel, whereas they show a higher resistance against higher temperatures and chemical influences. Due to the transparent wall, the running reactions could be easily observed in the tempering beaker made of glass.

Questionnaire to tempering beakers

Please respond to the listed questions and fax us these information for working out. We will send you a worked out offer with drawing as soon as possible.

1) Operating temperature of the tempering beaker:°C

2) Material of the tempering beaker: glass () V2A ()

3) Specifications to the tempering beaker:

a) Volume of the tempering beaker? Litres

b) Outer tube-diameter:mm

c) Inner tube-diameter:mm

d) Connection version of tempering jacket?

Glass olives () DN 15 flange () GL18 with plastic olive ()

Others (.....) spherical ground joint ()

4) Accessory

a) Metal adapter for DN 15

b) Seal silicon () PTFE ()

c) Flexible metal tube, thermal insulated, with double sided thread connections M16x1, suitable for standard thread of circulation thermostat

d) Length in metre: 0,5 () 1,0 () 1,5 () 2 ()

Special length ()

9) Further comments or customer wishes

.....
.....
.....

Sender: Company

Street

Town/City.....

Contact person

Department

Telephone Fax

Please fax to: KGW-ISOTHERM **0049 / 721 / 95 897-77**

Waste disposal tanks

Type E

catalogue page 31 - 32

Construction

The waste disposal tank consists of a mechanical stable and noticeable red coated metal cover, in which the actually storage container is installed. The storage container consists of borosilicate glass (Duran), which is finished with a PTFE – coated silicone seal.

Thus, the waste disposal tank is usable for many chemical products and waste products. The single-hand screw cap with the integrated over-pressure safety ensures that no overpressure could occur in the container. The overpressure valve is not resistant against all chemicals, and therefore has to be considered as a wearing part. For a lot of applications is it possible to do without an overpressure valve. For storage of inflammable solvents, is it necessary to install an earthing ribbon in the lid. The star grip enables to open and close the container effortlessly.

Utilisation and Field of Application of the waste disposal tank

The waste disposal tank was especially designed to use at the laboratory bench. This tanks are for storage of chemicals and could also be used for disposal of chemical waste products (e.g. consumed solvents). For the actual storage container is made of borosilicate glass 3.3 DIN/ISO 3585 (Duran), most of the acids and alkaline solutions could be kept therein. The waste disposal tanks are available with volumes of 4, 8, and 15 litres.

Dewar flasks made of stainless steel

Type GSS and DSS

catalogue page 33 - 34

Dewar flasks made of stainless steel are a fracture proof alternative to the cylindrical glass Dewar flasks, and are often used as working flasks at laboratory benches. Comparing the evaporation rates for LN2 shows, however, that the glass Dewar flasks have a substantially low evaporation rate than the stainless steel Dewar flasks.

For a safer use, the flasks type GSS have a grip on the side. A loosely lain insulated plug could be offered as an accessory.

Hot and cold protection devices for measuring data logger

Type ITET

catalogue page 35 - 36

Construction

The product series ITET hot protection devices consist of a line of conventional and vacuum insulated protection containers for measurement data loggers or electronic equipment, which have the task to insulate the devices against a high (up to +600°C), or low (-100°C) ambient temperature. The penetration of warmth can neither be completely prevented by a vacuum insulation nor a conventional insulation. To prolong the insulating periods in spite of penetrating warmth, special thermal masses are utilised. These buffer the penetrating warmth and increase herewith the operating time of the electronics in the insulating container. The thermal mass could be a solid or a substance, which store the penetrating warmth by means of the phase transformation. Due to different superstructure, hot protection devices can overtake further additionally functions such as water proofness or compression.

Utilisation and Field of Application of hot protection device Type ITET

ITET hot and cold protection devices are for thermal insulation of measuring data loggers. In end-charge-and-discharge furnaces, enamelling furnaces, or baking ovens, the flasks enable that the data loggers could pass through the oven together with the product, and the data logger can measure and record the temperature course during the process at the critical points of the product. Long sensor cables (trailing cable) thus, are unnecessary.

Please ask for our ITET - brochure or complete the enclosed questionnaire. Apart from the standard program, utilisation of specific containers could be offered as well.

Questionnaire to technical requirements on a hot protection device

Please respond to the listed questions and fax us these information. We will send you a worked out offer with drawing as soon as possible.

1) Temperature range

- a) Oven pass through temperature max.°C
b) Oven passes through timemin.

2) Data logger

- a) Dimensions (length x width x height) mm
b) Probe version
c) Probe diameter mm
d) Number of probes
e) Maximum operating temperature of the data logger °C

3) Oven specifications

- a) Maximal inlet height mm
b) Forced-air oven () Yes () No
c) High relative humidity of air () Yes () No

4) Maximum outer measurements of the hot protection device

- a) Outer dimensions (length x width x height) mm
b) Maximum weight kg
c) Special holding devices

5) Further comments or customer wishes

.....
.....
.....
.....

Sender:

Company.....
Street
Town/City.....
Contact Person
Department
Telephone Fax

Please fax to: KGW-ISOTHERM **0049 / 721 / 95897-77**

Construction and Utilisation of cold traps

The cold trap's task is to condense certain substances from a flow of gas. This is obtained by leading the flow of gas through a cold trap filled with coolant, and herewith the substances condense on the cool walls of the cold trap. The more cool walls are in the cold trap and the more turbulence appear in the cold trap, the higher is the capacity of the cold trap. Apart from the illustrated connections illustrated in the catalogue, the cold traps could be constructed with customer specific joining elements (see drawing KF1).

Cold trap**Type GKF****catalogue page 37 - 38**

GKF is a high-capacity cold trap with two condensation-freezing walls and integrated Dewar flask. The trap is for gas cleaning by condensation and is often switched before the pump in vacuum systems. It is possible to use liquid nitrogen or an acetone-dry ice-mixture as a cooling medium. While erecting the cold trap, please be aware that there are not too strong mechanical powers affecting on the grinding connections.

For security reasons, the cold trap is fitted with an aluminium cover. A bottom-drain valve facilitates the condensation tapping. The vacuum connections consist of conical ground joint connections. As a special design, the cold trap could also be offered with different connection such as spherical ground joint, or small flanges.

Cold trap**Type KF 29 – K****catalogue page 39 - 40**

This cold trap was designed for the robust utilisation in laboratories, and is for gas cleaning by condensation. For the cold trap is hinged in the Dewar flask's two-part support ring (polyethylene, PE), the trap could be replaced with only a few hand movements in no time. Therefore, stand material will not be necessary. As a cooling medium, liquid nitrogen or an acetone-dry ice- mixture could be used. While erecting the cold trap, please be aware that there are not too strong mechanical powers affecting on the grinding connections.

The connections are offered by choice with either ball-and-socket joints (type KF 29 - K) or spherical ground joints and O-ring sealant (type KF 29 - OK). In special design, the cold trap could be manufactured with different connections. Certainly, these cold traps will be supplied with different dimensions. Please inform us about the expected condensation capacity, or send us the data sheet "**Questionnaire about technical requirement of a cold trap**".

Chemistry pump device with two cold traps**Type CP****catalogue page 41 - 42**

The chemistry pump device is a mobile vacuum unit, which generates an oil-free vacuum with a vacuum pump. It is utilised wherever gases has to be cleaned of undesired substances. The moveable stand gives space for the vacuum pump that the pump device could be utilised in a very flexible way.

The pump device has two cold traps for gas cleaning, which could be used individual or parallel by valve timing. The cold traps are switched before the vacuum pump to prevent damaging the pump caused by penetration of dampness respective solvents. In reversed direction, cold traps can protect the recipient by preventing back diffusion of the vacuum pump's oil mist.

The manometer of version CP 1 shows the running cold trap's state of saturation. The vacuum pump is not part of the delivery. On request, vacuum pump with differing suction capacities could be offered.

In case a special cold trap or chemistry pump device is needed, please feel free to use the questionnaire cold trap to work out such a construction.

Questionnaire about technical requirements for a cold trap

Please respond to the listed questions and fax us the information. We will send you a worked out offer with drawing as soon as possible.

1) Condensation product

- a) Condensation material
- b) Condensation temperature max.°C
- c) Condensation quantity ml

2) Cold trap version

- a) Cold trap with Dewar ()
- b) Cold trap (similar to type GKF) ()

3) Cold trap connections

- a) Spherical ground joint () size
- b) Spherical ground joint with O-ring (Rotulex) () size
- c) Conical ground joint () size d) glass olive () size
- e) GL with plastic olive () size f) Schott flange () size
- g) Small flange NW () size h) collar flange DN () size

4) Coolant version

- a) Liquid nitrogen () b) dry ice ()
- c) Different coolant ()

5) Stand

- a) Moveable pump cart () b) stationary floor rack ()

6) Further comments or customer wishes

.....

.....

.....

.....

.....

Sender:

Company

Street

Town/City.....

Contact person

Department.....

Telephone **Fax**

Please fax to: KGW-ISOTHERM **0049 / 721 / 95897-77**

Construction

The level control device is for the automatic refilling of liquid nitrogen (LN2) in an open Dewar flask. The refill device keeps constant the level of liquid nitrogen in the Dewar flask to be filled.

The LN2 level controller type "Level control LN2" consists of a control device with two sensors, which could be utilised together with a LN2 storage container and a LN2-transfer siphon with a 24 volt magnetic valve.

The "Level control LN2" observes and regulates the liquid level with two PT100 sensors in a Dewar flask to be filled. In case the liquid level falls below the minimum-sensor, the magnetic valve at the container will open. On account of the operation overpressure generated in the container by own evaporation, the liquid nitrogen flows from the storage container in the Dewar flask to be filled. When reaching the maximum-sensor, the magnetic valve will close again. To avoid malfunctions, please take into account that the sensors does not have a direct contact to deep cool components (e.g. to the Dewar flask's metal wall).

As an accessory for the LN2 level control device, there are two different transfer siphons available.

The LN2-transfer siphons are usable for all storage containers with small flange connection NW50KF.

Transfer siphon No.1304 is for storage containers with firmly installed safety armatures. (e.g. APOLLO, JUNO).

Transfer siphon No. 1305 is for storage containers without firmly installed safety armatures. (e.g. type ALU).

Container for storing liquid nitrogen	Type APOLLO	catalogue page 45 - 50
	Type JUNO	
	Type ALU	

The containers of type APOLLO, JUNO, ALU are for storing and transporting liquid nitrogen. All the containers are vacuum insulated and have a super insulation foil in the vacuum room. The standard supply range comprises containers with a capacity of 7 to 300 litres.

LN2 storage container Type APOLLO catalogue page 45 - 46

The container type APOLLO is a robustly stainless steel container for storing liquid nitrogen in complete version. This type has a multilayered super insulation in the vacuum room, handles, safety armature, small flange connection NW 50 KF, castors, transfer siphon with transfer tube, own pressure build-up device, and level indication. This container is available with a volume of 50 to 300 litres.

LN2 storage container Type JUNO catalogue page 45 - 46

The container type JUNO is a robustly stainless steel container for storing liquid nitrogen. This type has a multilayered super insulation in the vacuum room, handles, safety armature, small flange connection NW 50 KF, and castors from type JUNO 50 on. This container is available with a volume of 25, 50, and 100 litres.

There is an extensive accessories program at the user's disposal. This program consists of a transfer siphon, a transfer tube, a transfer tube with phase separator, and further small parts.

LN2 storage container Type ALU**catalogue page 49 - 50**

The container type ALU is a light weighted aluminium container for storing liquid nitrogen. This type has a multilayered super insulation in the vacuum room, handles, and a small flange connection NW 50 KF. The container is available with a volume of 7 to 100 litres.

An extensive accessories program is at the user's disposal. The program consists of a transfer siphon with safety armatures, a transfer tube, a transfer tube with phase separator, roller base and further small parts.

Container made of aluminium for storing of biological samples in liquid nitrogen**Type BIO****catalogue page 51 - 52**

Containers of type Bio 3 to Bio 40 are vacuum insulated container for storing and transporting biological samples with liquid nitrogen. All the containers are vacuum insulated and have a super insulation foil in the vacuum room. The standard supply range comprises containers with a volume of 3 to 40 litres LN2.

Further sizes or containers made of stainless steel on request.

KALTGAS-system for deep temperature cooling**Type KALTGAS****catalogue page 53 - 54****Function and Field of Application**

The KALTGAS system benefits from the high cooling capacity of liquid nitrogen. The latter is evaporated by means of a heating in the LN2 storage container. The deep cool gas reaches the sample through a flexible vacuum conduction. At the end of the flexible vacuum conduction, there is a heat exchanger, which warms up cool gas up to the desired temperature, thus a constant flow of gas with a constant temperature is at disposal. For with KALTGAS-systems the actual tempering system of the test chamber is undockable, one single system could be utilised for different cooling applications, or tempering chambers.

KALTGAS is a very capable tempering system for cooling the samples in the temperature range of -180°C to $+195^{\circ}\text{C}$. Fast cooling down and very deep temperatures are the specific characteristics of the Kaltgas systems. Due to the module like construction, the system can be adapted without great efforts to the user's requirements. Thus, the system could be utilised for cooling samples in the open space or in a test chamber in the branch of material testing, deep temperature technology, cryotechnology, shock freezing, freeze drying, temperable reaction vessels, traction engine and torsional machine, etc. .

Please feel free to ask for further information or send us the enclosed questionnaire.

Certainly, you will receive further technical information about the single systems on request.

Questionnaire to Kaltgas system

Please respond to the listed questions and fax us the information. We will send you a worked out offer with drawing as soon as possible.

KALTGAS-system type

1) Temperature range

- a) Desired plus temperature°C
- b) Desired minus temperature°C
- c) Desired cooling down velocity°C

2) Desired duration of cooling process

- a) Minutes
- b) Hours
- c) Days

3) Temperature stability

Desired temperature stability°C

4) Version of the part to be tempered

- a) Material
- b) Weight
- c) Dimensions

5) Storage of the part to be tempered

a) In a tempering chamber, desired dimensions and please specify particular requirements:

b) Chamber is extant, please specify us the following data:

Dimensions

Type of insulation

6) Further comments or customer wishes

.....
.....
.....

Sender:

Company

Street

Town/City

Contact person

Department

Telephone Fax

Please fax to: KGW-ISOTHERM **0049 / 721 / 95897-77**

Bioreactors
Reaction vessels
Accessory for reaction vessels

TYPE BIO
TYPE TRGN

catalogue page 59 - 60
catalogue page 61 - 69
catalogue page 69 - 74

Bioreactors and reaction vessels are utilised in the branch of chemistry, biotechnology and process engineering. By utilisation of borosilicate glass 3.3 DIN/ISO 3585, a high chemical resistance as well as neutral conduct of the container compared against the dealt with good is ensured. Heatable reaction vessels can be used, depending on the version, from -150°C to +300°C.

All the reaction vessels produced by KGW – ISOTHERM are based on a plane flange–system of Schott (NW 60 to NW 200). With this standardised flange system, an extensive accessory and spare part program is at the customer's disposal. Due to the O - ring groove in the flask's flange, an easy and safe erection of the flask with suitable lid will be possible and ensures a high density.

The reaction vessels are offered, by standard, in three versions. Single walled, double walled, or triple-walled vacuum insulated flasks, which are produced with and without reaction vessel drain. The reaction flasks drain could be a spherical ground joint or a valve.

Different coolant connections are possible with double walled heatable reaction vessels. Besides the glass threads with unscrewable plastic olives, plane flange DN 15 and DN 20 are offered.

All the reaction vessels, even the standard versions, are only manufactured when ordered. Mainly, changes with connections or flanges could be offered without additional charges.

Apart from the listed types, further versions are always possible. By means of our CAD-system, we will submit an offer with drawing.

In addition to the single reaction vessels, complete reactor erections, consisting of stand, reaction vessel, lid made of glass or V2A, stirrer, and accessories, could be offered. An extensive accessories program completes the range of react or erections and reaction vessels.

6) Dynamic seal for stirrer

7) Coupling for stirrer

8) Accessories

- a) Stationary rack b) moveable rack c) rack according to customer wishes
- b) Flexible metal tube insulated for DN 15 metal adapter and connection to thermostats.
- Length in metres 0,5 () 1,0 () 1,5 () 2 special length.....

9) Further comments or customer wishes

.....
.....
.....
.....
.....

Sender:

Company.
Street.....
Town/City.....
Contact person.....
Department
Telephone Fax

Please fax to: KGW-ISOTHERM **0049 / 721 / 95 897-77**

Function and Field of Application of columns

Columns are utilised in many laboratories in the branch of chemistry and the process engineering. They are used for phase separation of liquid and substance mixtures. Fields of application are thermal separation processes such as distillation, rectification, extraction, and absorption.

All produced vacuum insulated columns by KGW - ISOTHERM are manufactured according to the directive 12492 "devices with vacuum insulation" produced and tested. Each column will be single tested with a temperature of +200°C. All columns are manufactured with opposite viewing stripes by standard. The in the tables listed types are only a selection of the best selling columns; changes in connection or size are possible.

Packed - columns type FK

catalogue page 77 - 78

Packed - columns have a good separation grade with great operation capacity with a small operation volume and low-pressure loss. In the lower part of the columns, a funnel is melted in to take the tower packing. The latter avoids a rim running of the column. When utilising smaller tower packing, firstly, larger tower packing has to be put in the funnel to prevent the smaller tower packing from falling through the drillings in the funnel.

The drillings ensure a free cross section of the funnel of the grinding connection's surface.

Vigreux - columns type VK

catalogue page 79 - 80

Vigreux - columns are far more suitable for utilisation in the vacuum than packed-columns, for the pressure difference is utterly small. They have compared to packed-columns a very little separation grade.

Apart from the standard columns further versions, sizes and types according to customer wishes could be manufactured. Although, all columns are available in heatable version (instead of vacuum insulation).

Special designs and customer specific alteration of standard products.

Cryostats made of glass for LN2 or LHe

Besides those in the catalogue-listed products, KGW - ISOTHERM also manufactures cryostats made of glass for utilisation of liquid nitrogen (77K) or liquid helium (4K). The cryostats are offered as bath-cryostats both with and without optical windows, and some versions even allow utilisation with variable temperatures (300K to 77K). Additionally, KGW-ISOTHERM offers racks, vacuum insulated LHe transfer siphons made of metal, with and without stop valve, as well an extensive accessory program for the cryostats.

Examples:

No.: 1 A bath-cryostat for LHe, with LN2 cooling jacket.

No.: 2 An optical LHe cryostat with four windows, for variable temperatures, with LN2 cooling jacket.

No.: 3 A bath-cryostat for LHe, with separate LN2 bath-cryostat, moveable rack, holding device, and V2A - lid.

No.: 4 An optical LHe bath-cryostat with windows, long test chamber and LN2 cooling jacket.

Customer specific Alterations of Standard Products

All Dewar flasks listed in the catalogue, could be changed according to customer specifications. This means that the Dewar flasks could be manufactured in lengthened and shortened version. Additionally, the flasks are available in non-silvered version (with or without implosion protection), with one viewing stripe or two opposite ones. Although, modifications with the metal protection covers are possible, e.g. holding bolts could be mounted on the covers to fix the Dewar flasks in an inset device.

LN2 and LHe cryostat

No.: 1

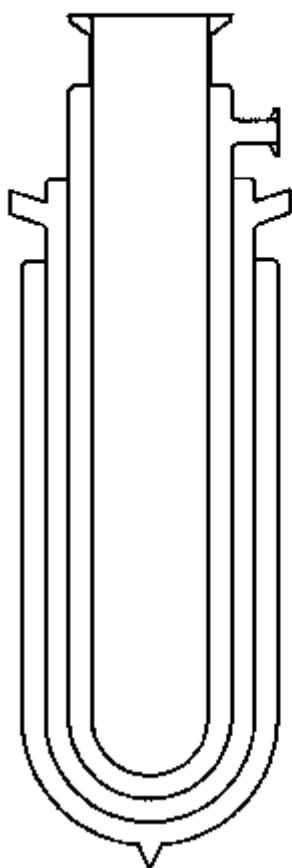

No.: 2

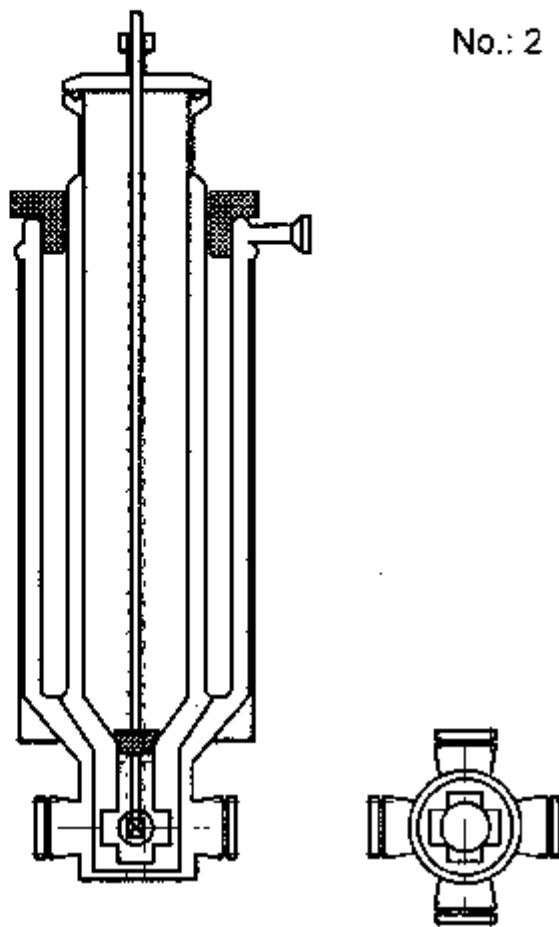

No.: 3

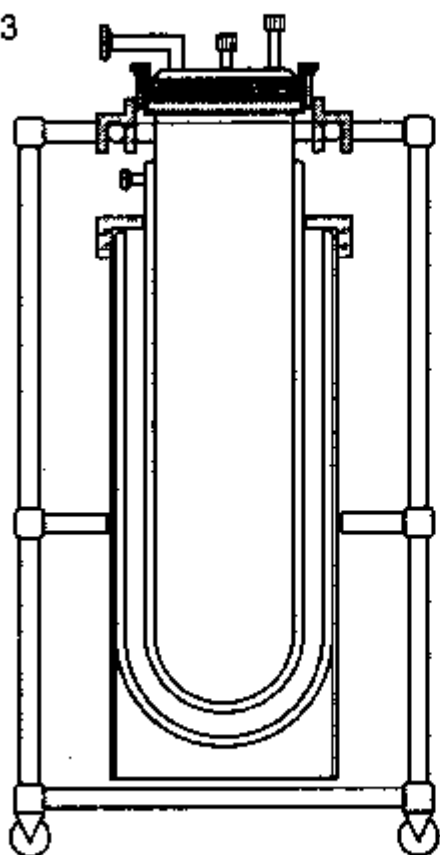

No.: 4

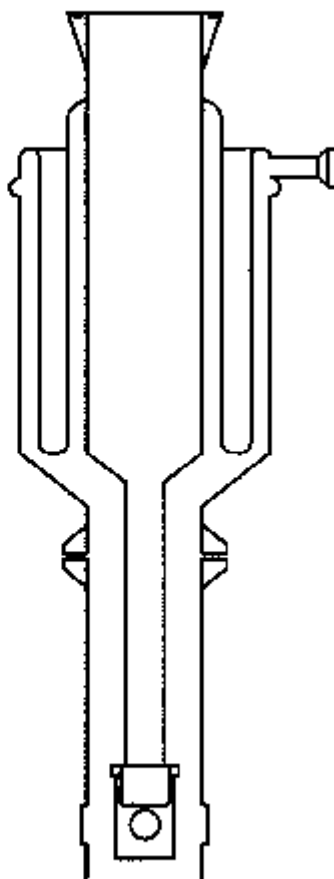

Manufacturing of special designs

KGW – ISOTHERM has a very good furnished glassblowing department, which enables us to produce special designs in standard product quality. On account of a, in the order process included, CAD-system, a two dimensional drawing will be made during the offer working out and will be sent to the customer with the quotation. Thus, the customer is enabled to check the most important data and dimensions in advance, and has a documentable drawing at his/her disposal for the later production of such a product. KGW – ISOTHERM has different verification devices such as a helium – leak testing device for density testing, a pressure test device for a calibrated pressure range from 0 to 4, an ultrasonic wall thickness measuring device for glass, several temperature test devices for thermal insulation measurement, and a system for measuring the evaporation rates (LN2 or CO2) of vacuum insulated containers (Dewar flasks).

In case, you need a special designed product made of glass, please send us a rough drawing via Fax (0049/721/95897-77) or via E - Mail (info@kgw.isotherm.de), or your written request; we will send you an offer with drawing according to the submitted information.

Examples:

No.1: A micro - distillation equipment.

No.2: A glass funnel with adsorbing column and V2A - cover (E DIN 19739-1).

No.3: A special designed cooler Kaltgas - glass reactor.

No.4: A corresponding Dewar.

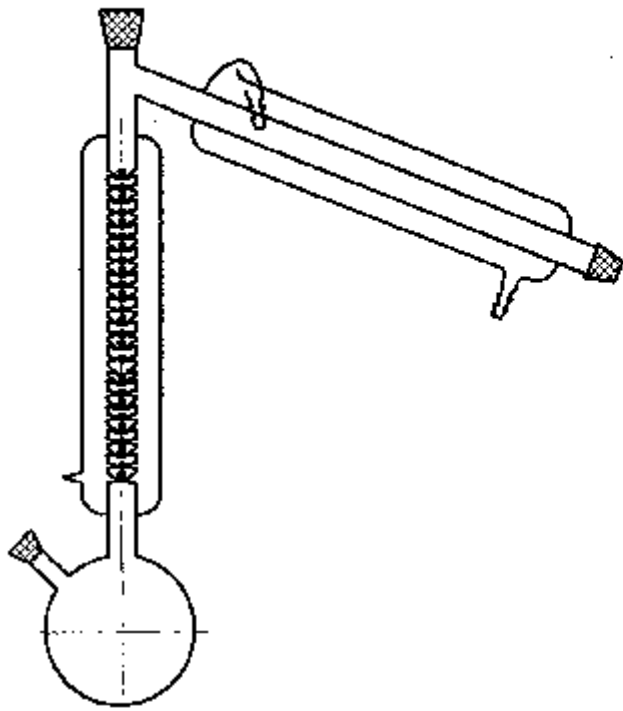

No.1

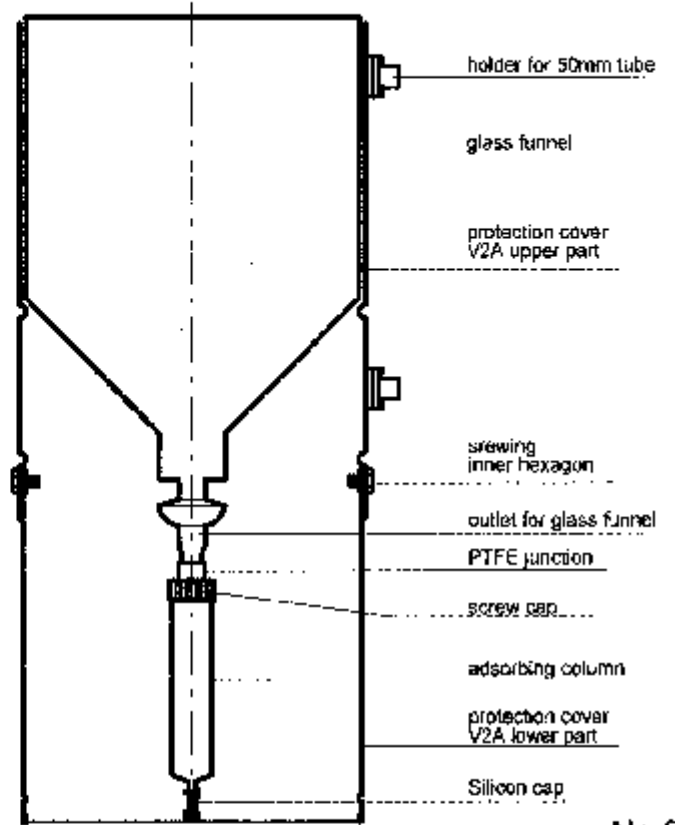

No.2

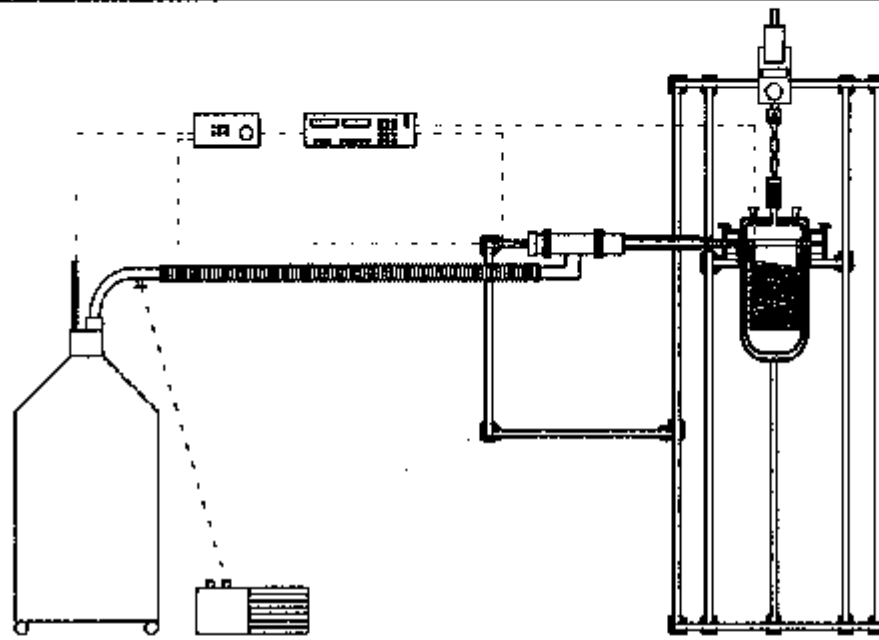

No.3

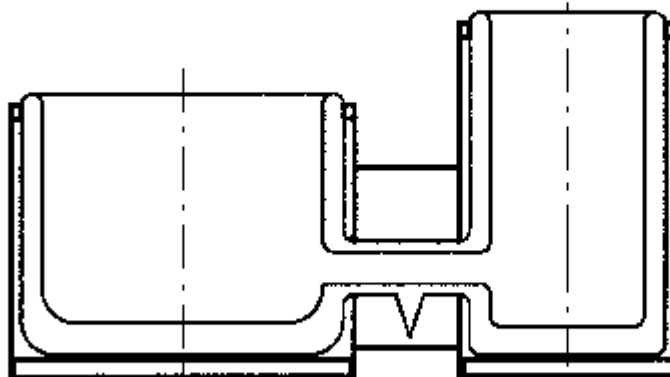

No.4