



# Technical data sheet for Dewar flasks with flat bottom type from FB 0 - 18 CAL

## Area of application

- laboratory technique
- medicinal technique
- Biotechnology
- for liquid or solid medias and solid matters (LN<sub>2</sub> oder CO<sub>2</sub>)
- Pressure-less space for coolants



Dewar flask FB 9 CAL without viewing stripes

## Features of performance

- reliably and economically
- Dewar flasks according to DIN EN ISO 16496
- glass material according to ISO 3585
- nominal capacity from 150ml to 2,1 litres
- protective casing made of stucco aluminium

Dewar flask FB 9 CAL with viewing stripes



## Description of complete flasks

### Types and accessories

- CAL = protective casing out of stucco aluminium

### Temperature ranges

- glass refill from -200°C to + 150°C, for a short time 200°C
- casing with mounting rubber and Latizell buffer from -10°C to + 60°C

### Pressure range

- pressure - less

## Description of glass Dewar flask

### Material

- borosilicate glass 3.3 ISO 3585

### Chemical characteristics

- hydrolytic resistance: according to ISO 719 (98°C)
- hydrolytic resistance: according to ISO 720 (121°C)
- acid resistance: according to ISO 1776
- alkaline resistance: according to ISO 695-A2

### Physical characteristics

- linear expansion coefficient:  $3,3 \times 10^{-6}$  1/K (in between 20-300°C)
- density: 2,23 g/cm<sup>3</sup>
- specific thermal capacity: 910 J/kg K
- transformation temperature: 525°C

### Vacuum

- $> 5 \times 10^{-6}$  mbar

### Silvering

- fully silvered

## KGW -ISOTHERM

Karlsruher Glastechnisches Werk  
76185 Karlsruhe Gablonzerstraße 6  
Tel: 0721 95897-0 Fax: 0721 95897-77  
E-Mail: info@KGW-ISOTHERM.COM  
Internet: www.KGW-ISOTHERM.COM



# Technical data sheet for Dewar flasks with flat bottom type from FB 0 - 18 CAL

## Special types

- Dewar flask with loosely lied-on plug
- with opposite viewing stripes

## Safety advises and regulations

- always wear protective glasses and protective gloves
- national regulations for laboratories
- company- internal regulations
- safety regulations for handling with liquid gases

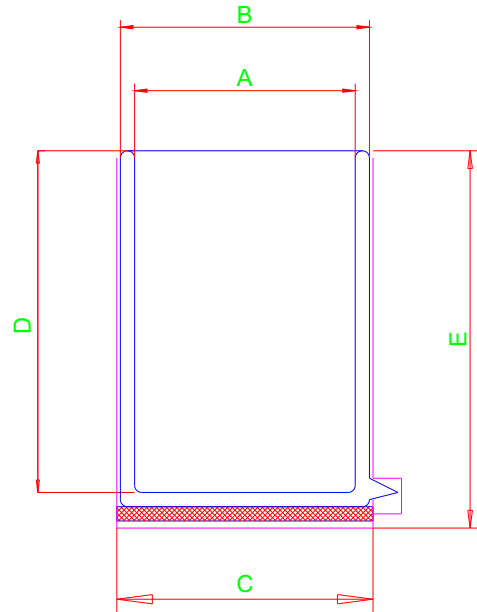

### Technische Angaben / Technical Specifications / Caractéristiques techniques

Typ	max. Inhalt	A	B	C	D	E	Gewicht	Standzeit LN2	Verdampfungsrate LN2
Type	max. Content						Weight	Holding time LN2	Evaporation rate LN2
Types	Capacité max.						poids	Durabilité LN2	Taux d' évaporation LN2
	ca. [ ml ]	mm	mm	mm	mm	mm	ca. [ kg ]	ca. [ h ]	ca. [ L / d ]
FB 0 CAL	150	37	50	58	140	170	0,3	12	0,25
FB 1 CAL	250	47	60	72	140	170	0,4	13	0,35
FB 3 CAL	450	57	70	81	185	220	0,5	28	0,35
FB 6 CAL	650	67	80	90	185	220	0,6	32	0,4
FB 9 CAL	850	77	95	105	185	220	0,9	32	0,55
FB 12 CAL	1200	90	115	124	185	225	1,2	33	0,7
FB 18 CAL	2100	107	130	140	235	275	1,8	52	0,9

Angaben Verdampfungsrate für Vollversilberung / Data evaporation rate for fully silvered / Taux d'évaporation des données pour complètement argenté

### Artikel-Nummern / Article numbers / Référence

#### Vollversilberung / fully silvered

#### complètement argenté

Typ	Artikel Nr.	Stopfen für Typ	Artikel Nr.
Type	Article No.	Plug for type	Article No.
Types	Référence	Bouchon pour type	Référence
FB 0 CAL	1151	FB 0 CAL	1651
FB 1 CAL	1152	FB 1 CAL	1652
FB 3 CAL	1153	FB 3 CAL	1653
FB 6 CAL	1154	FB 6 CAL	1654
FB 9 CAL	1155	FB 9 CAL	1655
FB 12 CAL	1156	FB 12 CAL	1656
FB 18 CAL	1157	FB 18 CAL	1657

#### Sichtstreifen / viewing stripes

#### rubans visuels

Typ	Artikel Nr.
Type	Article No.
Types	Référence
FB 0 CAL	1161
FB 1 CAL	1162
FB 3 CAL	1163
FB 6 CAL	1164
FB 9 CAL	1165
FB 12 CAL	1166
FB 18 CAL	1167

### KGW - ISOTHERM

Karlsruher Glastechnisches Werk  
 76185 Karlsruhe Gablonzerstraße 6  
 Tel: 0721 95897-0 Fax: 0721 95897-77  
 E-Mail: info@KGW-ISOTHERM.COM  
 Internet: www.KGW-ISOTHERM.COM